

Installation instructions



- AKO-D14112
- AKO-D14212
- AKO-D14312
- AKO-D14123-2
- AKO-14220
- AKO-D14223
- AKO-D14320
- AKO-D14323

3- Wiring

The probe and its cable should **NEVER** be installed in the same conduit as power, control or supply cables.

1- Warnings

- Using the equipment without following the manufacturer's instructions may affect the device's safety requirements. To ensure that the device operates correctly, only probes supplied by AKO should be used.
- The unit must be installed in a location protected from vibrations, water and corrosive gases, where the ambient temperature does not exceed that shown in the technical data.
- To ensure a correct reading, the probe must be situated in a location without any external heat influences except for the temperature which is being measured or controlled.
- The power supply circuit must be provided with a main switch rated at least 2 A, 230 V, located close to the equipment. The cables will enter through the back and should be type H05VV-F or H05V-K.
- The gauge will depend on local regulations, but should in no case be less than 1 mm².
- Connecting wires for the relay contacts should be sized 2.5 mm².
- Between -40 °C and +20 °C, if the probe NTC is prolonged till 1.000 m with a minimum of cable 0,5 mm², the maximum deviation will be of 0,25 °C (extension cable for probe ref. AKO-15586)
- NOTE:** Equipment not compatible with AKO-14917 (external communication module) and AKO-14918 (programming key)

2- Installation

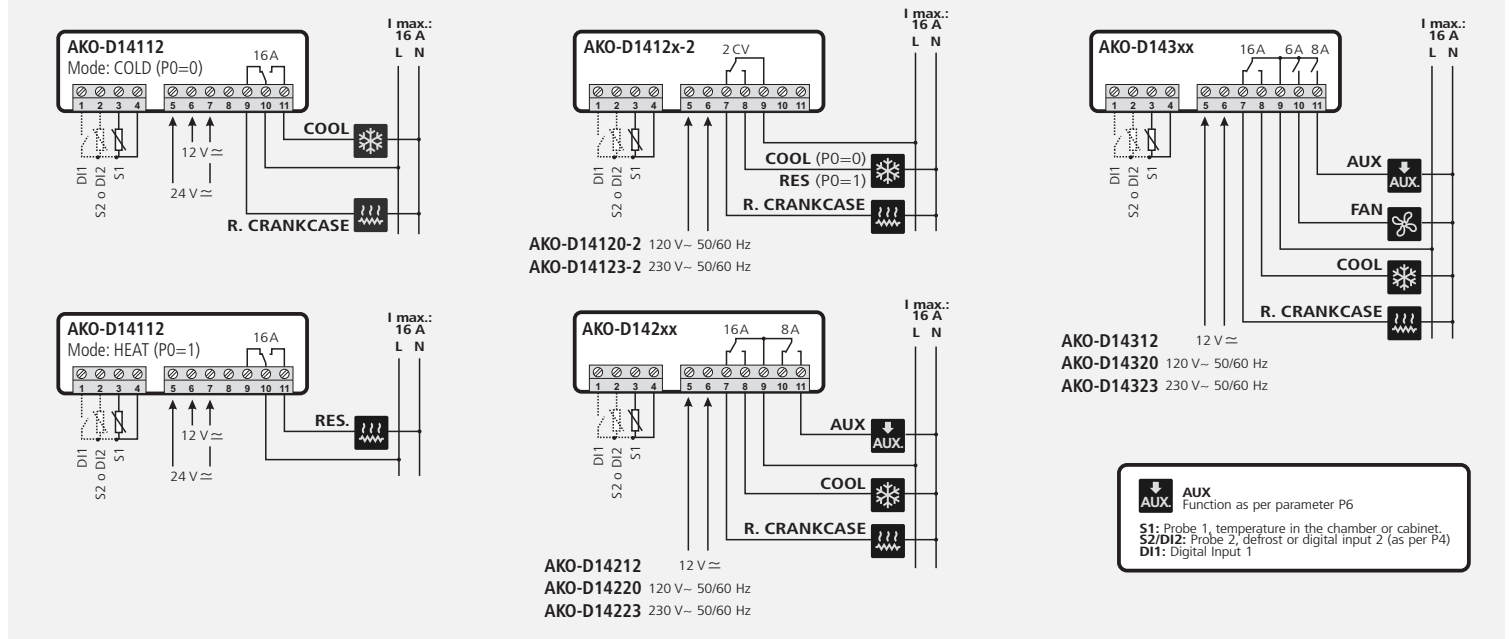
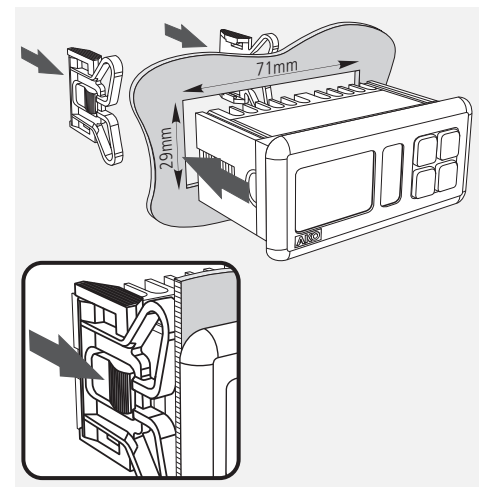

4- Operation

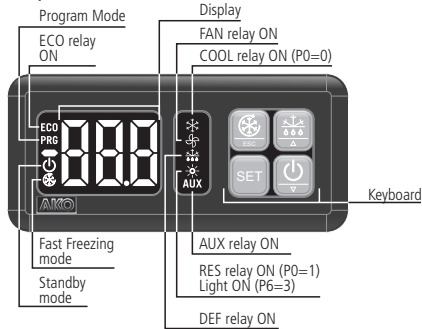

ESC key /

Press for 5 seconds to start/stop Fast Freezing mode (rapid cooling).
In the programming menu, exit without saving parameter, return to previous level or exit programming.

SET key

Press for 5 seconds to modify the set point (SP).
Press for 10 seconds to go to the programming menu.
In the programming menu, go to the level displayed or accept the new value while setting a parameter.

Up key /

Pressing for 5 seconds starts/stops defrosting.
The programming menu, allows you to scroll through the various levels or, during the setting of a parameter, to change the value.

Down key /

Pressing for 5 seconds activates Standby mode, pressing for 2 seconds returns the equipment to normal mode. In Standby mode, the equipment performs no actions and only the indicator is displayed on the screen.
The programming menu, allows you to scroll through the various levels or, during the setting of a parameter, to change the value.

4.1- Access to set point and programming

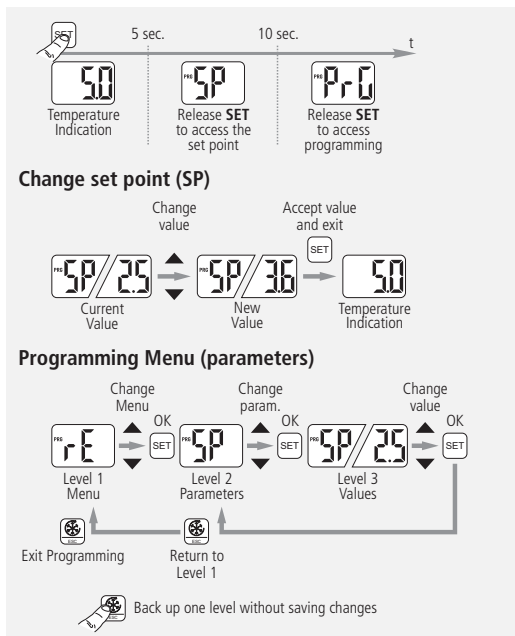

5- Start-up

On power-up, the equipment will start up in Wizard mode (P3 / 1 flashing), press ▲ or ▼ to select the most appropriate application and press SET.

- 1: Multipurpose
- 2: Frozen
- 3: Fruits and vegetables
- 4: Fresh fish
- 5: Soft Drinks
- 6: Bottle racks
- 7: AC
- 8: Heat / Incubators

The wizard will configure the parameters of the equipment for the chosen application (see table "Default settings by application").

AKO ELECTROMECÁNICA S.A.L.
Av. Roquetes, 30-38
Barcelona (España)
08812 Sant Pere de Ribes
www.ako.com
Tel. (34) 938 142 700
Fax (34) 938 934 054
www.ako.com



